

... for a safe traffic guidance

for a safe



traffic

guidance

Your wish is our command

Table of contents

System *MarkLED*[®]

pages 4 - 7

<i>MarkLED</i> [®] – General Information	page 4
<i>MarkLED</i> [®] – Technical Data	page 5
<i>MarkLED</i> [®] – Installation and Product Line	page 6
<i>MarkLED</i> [®] – Different Options and Examples	page 7



MarkLED[®] – Optical Guidance Devices in Tunnels

System *FlatLED*[®]

pages 8 - 11

<i>FlatLED</i> [®] – General Information	page 8
<i>FlatLED</i> [®] – Technical Data	page 9
<i>FlatLED</i> [®] – Installation and Product Line	page 10
<i>FlatLED</i> [®] – Different Options and Examples	page 11



FlatLED[®] – Guidance Devices that can be driven over

System *CircLED*[®]

pages 12 - 15

<i>CircLED</i> [®] – General Information	page 12
<i>CircLED</i> [®] – Technical Data	page 13
<i>CircLED</i> [®] – Installation and Product Line	page 14
<i>CircLED</i> [®] – Different Options and Examples	page 15



CircLED[®] – Round-about and Lane Lighting

System components

pages 16 - 19

Control Systems	page 16
Power Supply	page 17
Programming Unit	page 17
System cable	page 18
Adhesives and Sealants	page 18
Junction Boxes	page 18
Joint Sealing Compounds	page 19
Potting compound	page 19
Guard Plate for <i>MarkLED</i> [®]	page 19
Cold-Temperature Mortar	page 19



Optical Guidance Devices for Safe Traffic Routing



Optical Guidance Device, Model **MarkLED®**(white)



Round-about Lighting, Model **CircLED®** (blue)



This brochure provides an overview of our product line of optical guidance devices for roundabouts and roads. We have detailed information, documentation, certificates and test certificates for each system and product which we would be happy to send if you are interested. Just ask for the information by e-mail or by phone, we would be glad to advise you!

Why Have Optical Guidance Devices?

An optical guidance device improves recognition of lanes, particularly during times of poor visibility (at night, fog, etc.) as well as vulnerable traffic areas such as tunnels, curves or roundabouts. The signals provide a very high degree of safety for traffic, particularly during around the clock operation.

Over the past few years, GIFAS has devoted a lot of time to the new and further development of optical guidance systems. Past experience and input from accredited expert committees have been of great benefit. This blending of theory and practice has made it possible for GIFAS to optimize existing systems in terms of the criteria "costs, functionality and maintenance" and to turn them into high-end systems, made in Switzerland.

The GIFAS systems have distinguished themselves beyond their technical qualities by offering maximum convenience to their customers (customized solutions, project management, documentation, after-sales service).

Optical Guidance Device System *MarkLED*[®]



MarkLED[®] Plug-In Upper and Lower Parts



MarkLED[®] Upper Part

System Description

Continued Development

The **MarkLED**[®] product has been improved for a second time. This was again based on practical experience with over 20,000 standard units that have been installed up to now. This time, however, the innovations did not primarily affect the product (upper part and lower part): all of the adjustments have to do with improving the installation process.

The System

The **MarkLED**[®] is a cable-guiding system with current carried through direct connections. This allows us to reach a very high efficiency factor (> 80%) and to remain within the limits for electromagnetic compatibility (EMC). By using state-of-the-art LED technology, power consumption is now only 40 mA per unit with increased light intensity. Thus we can lay cables with approx. 60 modules max. Thanks to the high energy efficiency, the power consumption is extremely low, which greatly contributes to keeping operating costs low. Based on these technical facts, we are able to meet the regulations set forth by the German Federal Highway Research Institute (BAST-Deutschland - Bundesanstalt für Strassenwesen) which also apply to us and other countries.

All in all, we can proudly say that our **MarkLED**[®] system is even easier to install, is new, but has added convenience to maintenance; this all being the logical consequence of innovation and our striving to always be the "best in class" !

MarkLED[®] Upper part

MarkLED[®] The proven upper part - the **MarkLED**[®] luminary, with its beautiful and elegant form and a housing made of crystal clear special plastic (Macrolon). The outer surface is nano-coated (anti-static and thus highly dirt-repellant and anti-corrosive). The electronics is installed from below and is completely surrounded by neutral, white grouting. The brightness and other functions, such as dimming, flashing, blinking of the lighting module can be easily controlled by the system control units and can also be influenced from the tunnel control center or an automatic light control system.

Current Collector

The current collector constitutes the actual «core» of the system. It is not only responsible for transmitting the current, mechanically speaking; it is also the «support» for the individual module. The current collector consists of an upper and lower part and combines various system functions.

1. Incorporation of the 2-pole supply line in a prepared "bed" shaped to match the stranded wire (impermeability).
2. Current transmission from the supply line to the contactpin.
3. The installed current collector is placed in the groove with sealants and adhesives.
4. The "disc" forms a clean base for the signal unit, and any structural irregularities can be evened out.

Additional System Components

For the overall function of the system, additional system cables (2 individual strands of wire), a cable conduit and the control units are required (refer to page 4).

Light emission schematic

The **MarkLED** System meets the regulations set forth by the German Federal Highway Research Institute (BAST-Deutschland - Bundesanstalt für Strassenwesen), and has been certified with the corresponding test certificate

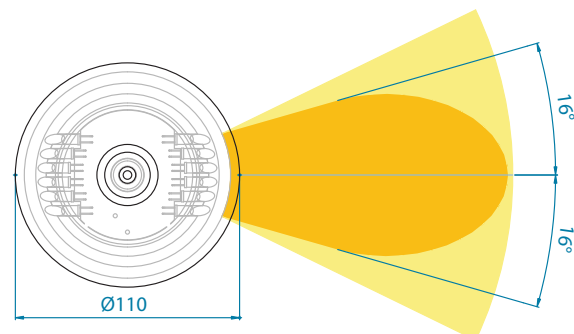
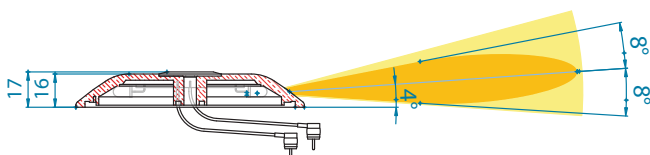

MarkLED® System – Technical Data



MarkLED® Electronics sealed with sealing compound

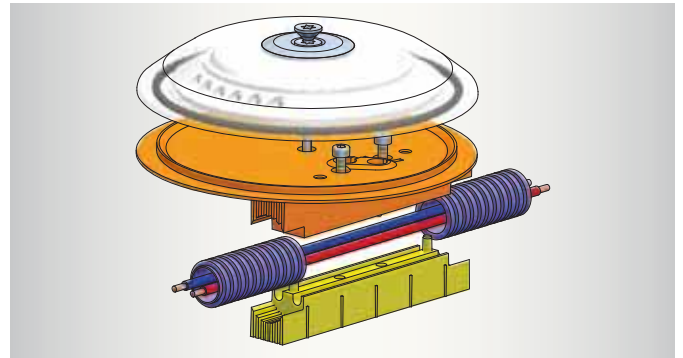

MarkLED® the basic principle

Technical Data

Connecting and sealing technology

In order to ensure that the light module can be easily moved or removed, we have paid a lot of attention to the Connecting and sealing technology.

The principle **MarkLED®**

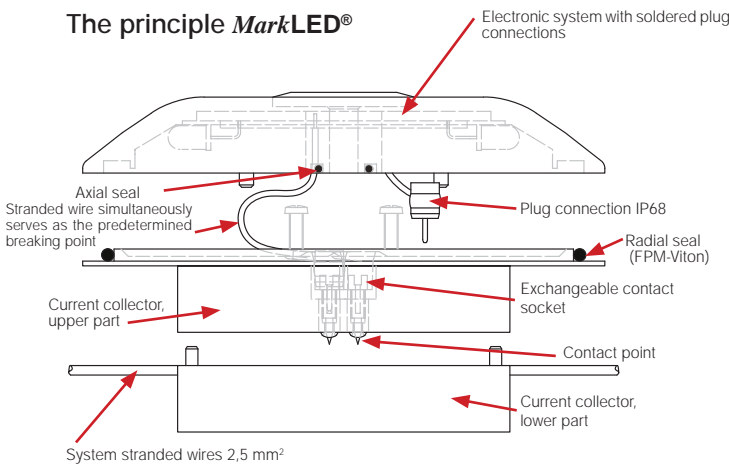

The operating voltage is 16–40 VDC (low voltage). The current is transmitted from the supply line (special stranded wires 2.5 mm²) through the contact socket (in the current collector) via cables and plug connection to the printed circuit board in the **MarkLED®** on which the LEDs (light-emitting diodes) have been soldered. The contact point on the current collector is sealed with two o-rings. The plug-in construction and the way the seals have been arranged must ensure **absolute impermeability on the one hand** and allow for simple exchange on the other hand. Tests are conducted (protection class **IP68 = completely dust-proof and water-pressure tight**) to confirm that the objective has been met.

Control Units

The control units required for the supply or control of the light module, resp., are very small and space-saving and may be integrated in existing distribution systems or control cabinets. A small distributor may be installed in a suitable place if needed. Our scope of supply includes 4-channel and 1-channel control units (see our main catalog for details).

The basic principle

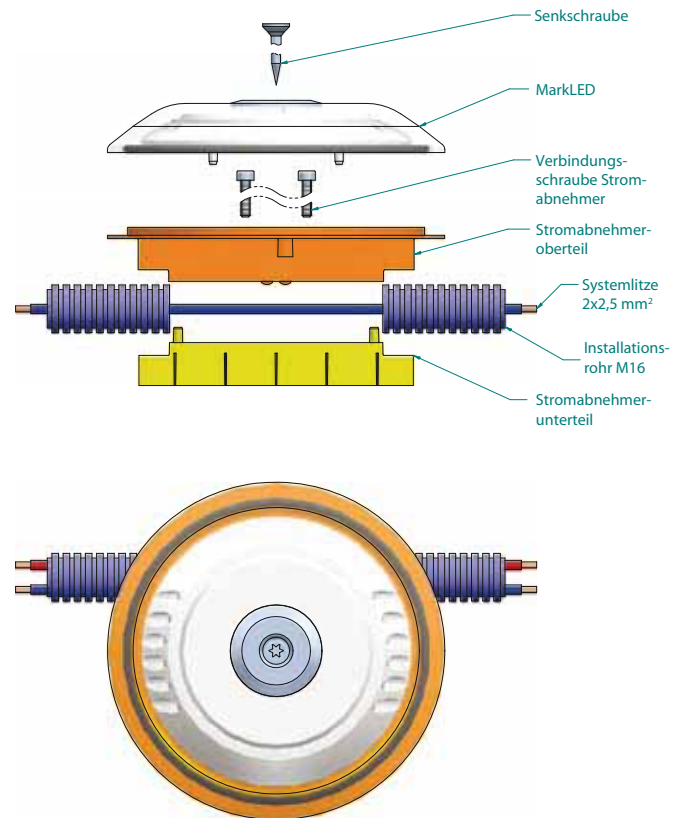

Technical Data for Signal Unit **MarkLED®**

Single or double-sided with 6 LEDs each	
Lamp color:	white (acc. to standard EN 12966-1:2002)
Light intensity:	> 30 cd
Protection category:	IP68
Protection class:	III
Elect. operating data:	24 VDC (range 16-40 VDC)
Power consumption:	40 mA
Color:	colorless, crystal clear
Dimensions:	ø 110 mm, height 16 mm
Light transmission:	approx. 9 mm above ground

MarkLED® System – Installation – Range of Products



The current collector is installed over the stranded wires



Seal the groove with sealant and adhesives Installation

Installation

The goal of the system design was to make installation as easy as possible in order to attain the greatest efficiency. It was also just as important that future maintenance be kept to a minimum and as efficient as possible.

The Installation Procedure:

- 1st Step: Control unit set up, cable is run to the shoulder
- 2nd Step: Measure locations
- 3rd Step: Dry mill the groove (6 x 15 mm) into the shoulder
- 4th Step: Pull in system stranded wires
- 5th Step: Insert the system stranded wires into the lower part
- 6th Step: Put on the upper part and screw it down
- 7th Step: Insert the current collector into the groove in the shoulder (secure with Permabond)
- 8th Step: Seal groove with bitumen grouting
- 9th Step: Drill a mounting hole Ø 5 mm, insert a screw anchor
- 10th Step: insert the contact pins from the upper part into the lower part
- 11th Step: Set **MarkLED®** upper part on top

Range of Products:

Range of Products

Item.	Description
024833	Signal Unit MarkLED, double-sided 6x white, operating current 40 mA, incl. V4A 4.5x50 mm mounting screw, V4A Ø 30mm cover and Ø 5 mm anchors (in packs of 20)
026692	Signal Unit MarkLED, single-sided 6x white, operating current 40 mA, incl. V4A 4.5x50 mm mounting screw, V4A Ø 30 mm cover and Ø 5 mm anchors (in packs of 20)
037449	Current collector I, to be inserted in concrete groove, consisting of upper and lower parts, incl. V2A KA 3x20 mm mounting screws (in packs of 20)
037457	Current collector II, to be inserted in asphalt groove, consisting of upper and lower parts, incl. V2A KA 3x20 mm mounting screws (in packs of 20)
020669	4-Channel control unit --> page 16
021248	1-Channel control unit --> page 16
020320	Programming device for 4-channel control unit --> page 17
029597	Power supply unit for 4-channel control unit --> page 17
039573	System cables for MarkLED, single-core cable, 2.5mm ² , black--> page 18
039572	System cables for MarkLED, white sheath --> page 18

MarkLED® System – Different Options and Examples

Because the practical conditions vary so much, we have always strived to manufacture special versions of the MarkLED®. These project-based solutions also became necessary since it became impossible to mill the grooves due, e.g. to the great quantities of reinforced concrete or the extremely poor condition of the shoulders. At other times there wasn't even a shoulder.

This all illustrates the fact that GIFAS is not just a manufacturer of standard products, but a company that works with its project teams to develop custom-made solutions. Below are some examples of how the MarkLED® system has been used in "unconventional" ways.

Based on our experience, we have found that customized and special solutions are developed for about 20 – 25% of all guidance device system projects. In these special cases, GIFAS supports the project teams in terms of technical considerations, drafting, creating CAD documents as well as putting together the cost estimates.

Example 1



In this example milling a groove is out of the question since extensive parts of the tunnel do not have a shoulder, but have more cover plates and/or "open" supply channels. The system stranded wires were led through the surface cable channel in cable ducts, secured with cable clamps, and wherever a MarkLED® was located, two holes were bored slanting upwards on the curb: the stranded wires were pulled through once, the MarkLED® was positioned according to standard and the stranded wires were run back into the channel.

Example 2



In situations where there is no shoulder or any pipe system whatsoever, there is another possibility to install the MarkLED®, which is to us an AP-solution. In this case, a MarkLED® was screwed onto an AP-housing, whereby the MarkLED® has no current collector, but rather has direct output with stranded wires. The AP modules can be supplied with power through a cable or the system stranded wires.

Example 3



This design has also been used many times already: MarkLED® that have output with stranded wires or a cable, i.e. no current collector. This is a good solution if the MarkLED® has to be mounted directly to a wall (e.g. on New Jersey-type barriers) or if the stranded wires are pulled through the supply channel in cable conduits, and if a MarkLED® is in a shaft and a socket/junction box is mounted from where the MarkLED® connecting cable is run onto the shoulder.

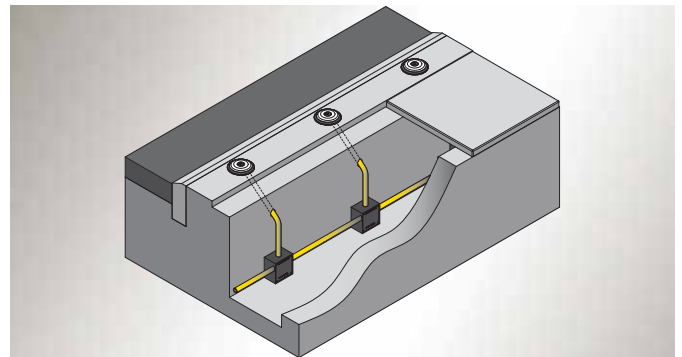

This is a schematic of the situation with the MarkLED® as described above and the way power is supplied through stranded wires laid in pipes.

FlatLED® System – General Information



FlatLED® Complete Module



FlatLED® Upper Part

System Description

Ever since optical guiding devices have become a topic of discussion, flat systems that can be driven over have also been part of the discussion. Over the past few years, this need has become clearer and several products were developed for the market.

GIFAS also accepted the challenge and completely revised the prototype of the FlatLED®. The new generation of the FlatLED® now meets all of the more recent guidelines (BAST, etc.) and is also a state-of-the-art device.

The most noticeable feature of the new design is the continuous light strip that has replaced the previously used 6 individual light conductors. This made it possible to correct the angle of the light beam and to further increase the intensity of the light.

The underground version of the FlatLED® is totally compatible with the MarkLED® system. This means that both models can be operated in the same line (channel) and they both require the same system components, from the cables to the controls.

The FlatLED® is designed to be driven over, even by snow plows, as proven through a series of tests.

The FlatLED® module is installed directly into the road surface (asphalt, concrete or the like). The brightness of the light emitted (LED) can be controlled and adjusted by a control system.

The Set-Up

The entire product, made up of the structural elements upper part, electronic unit (in the housing with the LED) and the lower part. Any additional installation materials required, such as screws (V4A), seals, etc. is provided.

The Set-Up

The entire product, made up of the structural elements upper part, electronic unit (in the housing with the LED) and the lower part. Any additional installation materials required, such as screws (V4A), seals, etc. is provided.

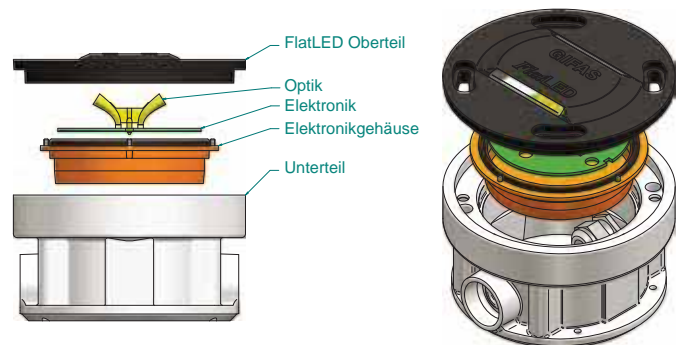

The FlatLED®

- Housing and upper part are made of special plastic, abrasion-resistant and can be driven over
- Light emission surfaces are nano-coated (anti-static to provide a high degree of dirt repellency and anti-corrosion protection)
- The electronic system (molded into the electronic system housing) is placed on the cover from below
- Can be fit with LED on one or both sides
- The light module is installed directly underground
- The brightness of the light module is easy to adjust with the control unit and can also be controlled through the automatic light control unit or directly from central controls in the tunnel.

i A reference list and detailed description of the system components is available upon request.

Light Emission Schematic

The FlatLED® system meets the regulations set forth by the German Federal Highway Research Institute (BAST-Deutschland - Bundesanstalt für Strassenwesen), and has been certified with the corresponding test certificate.

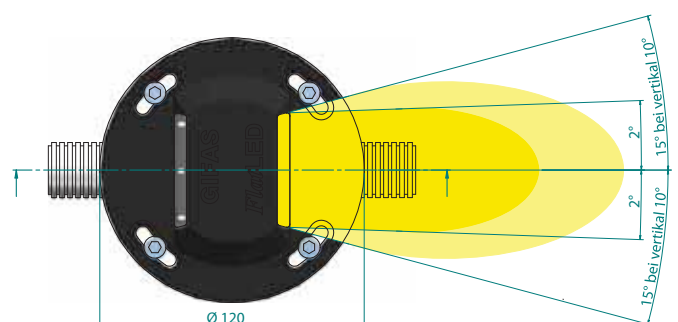
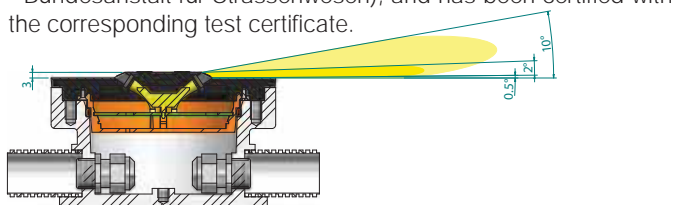

FlatLED® System – Technical Data



FlatLED® Lower Part with Upper Part and Electronic System



FlatLED® Lower Part

Technical data

Connecting Technology

The operating voltage is 18-44 VDC (low voltage). The current is transmitted from the supply line (special stranded wires 2.5 mm²) through standard commercial connecting clamps to the circuit board in the FlatLED®, to which the LED (light-emitting diodes) have been soldered.



Technical data

Single or double-sided with 6 LEDs each
 Lamp color: white (acc. to standard EN 12966-1:2002)
 Light intensity: 30 cd
 Protection category: IP68
 Protection class: III
 Elect. operating data: 24 VDC (range 18-44 VDC)
 Power consumption: 80mA
 FlatLED upper part color: black (RAL7021)
 Housing lower part color: natural
 Dimensions: Ø 120 mm, height 70 mm
 Height above road surface: 3 mm
 Temperature resistance: bis - 40°C
 Axle load > 20t

Other colors available upon request

Control Units

The control units required for supplying and/or controlling the light modules are very small and space-saving and can usually be integrated in existing distribution systems or control cabinets. A small distributor may be installed as needed. Our scope of supply includes 4-channel and 1-channel control units (see page 16 for a detailed description).

Sealing Technology

The overall design of the individual components was based on a high degree of impermeability. Protection class IP68 is attained provided the assembly is performed by experts.

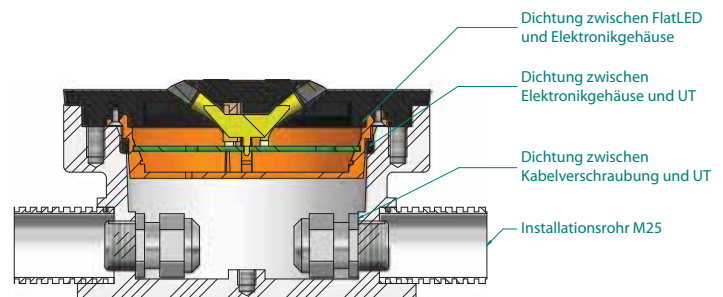

FlatLED® System– Installation – Range of Products



Boring core holes in the road surface / cable conduit



Molding with 2-K mortar

Installation

Relatively simple installation that was planned for in the development stage. The construction and installation procedures were specifically coordinated and optimized.

The Installation Procedure:

- 1st Step: Set up the control system, cable conduit to shoulder
- 2nd Step: Measuring locations
- 3rd Step: Dry-milling a groove in the road surface
- 4th Step: Bore core holes, spray out the holes
- 5th Step: Lay special stranded wires and guide into the lower part of the housing
- 6th Step: Insert the lower part into the core hole (use assembly jig) with 2-K mortar (or other suitable mortar)
- 7th Step: Connect and install the upper part of the **FlatLED®**
- 8th Step: Fill the core hole completely with bitumen sealing compound or 2-K mortar
- 9th Step: Lay glass fiber cord as cable protection und then fill in the groove (close) with bitumen seala
- 10th Step: Pull through to piping

Assembly Jig for **FlatLED®** / **CircLED®**:

Gifas provides a suitable assembly jig for installing the **FlatLED®** / **CircLED®** on loan. This makes it possible to adjust to the ground



Products

Item	Description
030859	FlatLED upper part, two-sided 6x white, operating current 80 mA, incl. V4A M6x16mm mounting screws and spring washers
037772	FlatLED upper part, single-sided 6x white, operating current 40 mA, incl. V4A M6x16 mm mounting screws and spring washers
036158	FlatLED lower part, 1 KV M16x1.5 / 2 x Ø 4mm
036159	FlatLED lower part, 2 KV M16x1.5 / 2 x Ø 4mm
020669	4-Channel control unit --> page 16
021248	1-Channel control unit --> page 16
020320	Programming device for 4-channel control unit--> page 17
029597	Power supply unit for 4-channel control unit --> page 17
039573	System cables for MarkLED, single-core cable 2.5mm ² , black--> page 18
039572	System cables for MarkLED, single-core cable 2.5mm ² , white--> page 18
020157	Adhesive and sealant --> Page 18
028303	Joint casting compound --> Page 19
016425	Cold-temperature mortar --> Page 19
018821	Assembly jig for FlatLED / CircLED (is provided on loan from GIFAS)
035976	Installation pipe

Other designs available upon request.

From Page 16 onwards, you can find an overview of all system components required for a complete FlatLED® system

i Detailed installation instructions with pictures of the individual steps are available upon request.

FlatLED[®] System– Different Options and Examples

Successful projects lead to new ideas and new designs. This is certainly true for the *FlatLED*[®]: on the one hand, new products emerged (see the *CircLED*[®] on the following pages); on the other hand, new areas of application and ideas for a special purpose arose.

In general, the *FlatLED*[®] can be used anywhere vehicles might drive over it from time to time. Because of the small diameter of the *FlatLED*[®], particularly of its lower part, the *FlatLED*[®] is also able to withstand very high loads without any problems.

The *FlatLED*[®] system is also excellent for locations that are subject to vandalism.

In the examples below, we have selected two applications that represent many smaller *FlatLED*[®] projects where the *FlatLED*[®] system was used in unconventional situations.

Example 1



After having experienced significant incidents with automatic retractable bollards, it wasn't until an optical display of the movement (up – down) for the bollard was provided that the incidents subsided somewhat.



By installing the *FlatLED*[®] at ground level in the road surface, the movements could also be displayed optically (blinking) which led to a noticeable decrease in incidents.

Example 2



The initial situation: an existing lighting system in a typical pedestrian zone was simply not water-tight, i.e. the light sources, housing and "inner workings" just corroded away.



In cooperation with the builder, special UP modules with integrated *FlatLED*[®] systems were constructed that were the same size as the old in-ground lights, making it easier to exchange them.

CircLED® System – General Information



CircLED® Complete Module



CircLED® Various Colors

System Description

After the **FlatLED®** and **MarkLED®** were introduced, we started receiving more frequent inquiries from our customers as to whether these two signal light systems might be used in other applications, e.g. for parking lots or on walls for decoration or orientation, or for round-about traffic lighting.

Following several projects it became clear that while the systems could certainly be used for other purposes, but some parameters still had the potential for improvement, as e.g. the light emissions or also the fact that up to then we mostly used white LEDs.

Thus we developed a complete line of round-about lighting, the **CircLED®** line. This line basically consists of the same elements as the tried and tested **FlatLED®** system, but has a different radiation pattern:

instead of two parallel light beams as the **FlatLED®** has, the **CircLED®** has a 270 degree arc of light and, in addition, an angle of light that is adapted to the disposition of the round-about traffic.

Since the **CircLED®** can be used in various locations, the series offers a selection of 3 colors for the covers, namely black, gray and white. Thus light colors can be used in more sensitive areas while the black standard cover is mostly chosen for use on the street.

We also wanted our customers to be able to select colors that would be suitable for their projects: this resulted in the range of stock consisting of white, yellow, green, red, blue and orange.

So there is definitely a suitable combination of cover and light color for any application!

The **CircLED®** is installed in the same way as the **FlatLED®** and can safely be driven over, even by snow plows. The housing consists of the same special plastic as used for the **FlatLED®**; it is installed directly into the corresponding sub-street level surface (asphalt, concrete, gravel, soil or a similar substance).



CircLED® 3 Cover colors: black, gray and white.

i A reference list and detailed description of the system components are available upon request

Light Emission Schematic CircLED®

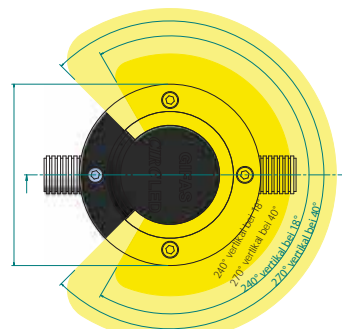
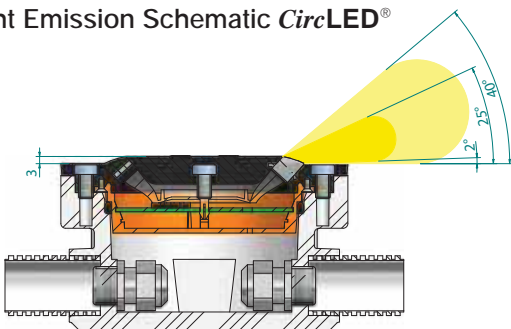

CircLED® System – Technical Data



Setting the lower part of the **CircLED®** in the soil / cable conduit



Fill in suitable material around the lower part of the **CircLED®**

Technical Data

Connection Technology

The operating voltage is 16-42 VDC (low voltage).
The current is transmitted from the supply line (special stranded wires or special cables 2x2.5 mm²) in a suitable installation pipe (Ø 25/19 mm, polypropylene) led through standard commercial connecting clamps on to the upper part of the CircLED® or to the electronic system where the LED (light diode) is installed.

Control Units

The control units required for supplying and/or controlling the light modules are very small and space-saving and can usually be integrated in existing distribution systems or control cabinets. A small distributor may be installed as needed. Our scope of supply includes 4-channel and 1-channel control units (see page 16 for a detailed description).

Technical data

270° Circular emission along a light strip (16 LEDs)
Lamp color: white, blue, orange, yellow, green, red
Light intensity: 18 cd (cool white)
Protection category: IP68
Protection class: III
Elect. operating data: 24 VDC (Bereich 16-42 VDC)
Power consumption: 120 mA (@ 24 VDC)
Color of upper part of housing: black, gray and white
Color of lower part of housing: natural
Dimensions: Ø 120 mm, height 70 mm
Height above road surface: 3 mm
Beam angle: 15°
Temperature resistance: bis - 40°C
Axle load: >20t

Other colors available upon request.

Sealing Technology

The overall design of the individual components was based on a high degree of impermeability. Protection class IP68 is attained provided the assembly is performed by experts.

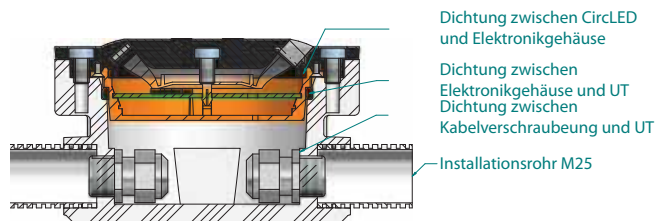

CircLED® System – Installation and Range of Products



Properly attached connecting clamps



Completely installed **CircLED®**

Installation

Relatively simple installation that was planned for in the development stage. The construction and installation procedures were specifically coordinated and optimized.

Notes on Installation

Please note that when in-ground lights are installed, the external influences are of crucial importance. A long and problem-free operation of in-ground lighting systems is only possible if they are installed with great care. In general: in order for the lights to function according to specification, you have to ensure that the installation is done carefully and professionally. The materials used must be selected very purposefully.

Preparatory Work

We are happy to provide you the necessary support you need in order to prepare for the structural work. GIFAS will provide you with a complete cost estimate to help you with your planning. Please note: In order to attain the best results, we highly recommend that you only use the materials we recommend!

Assembly Jig for **CircLED® / FlatLED®**:

Gifas provides a suitable assembly jig for installing the CircLED® / FlatLED® on loan. This makes it possible to adjust to the ground level exactly and to optimize the relocation of the component.



Range of Products

Color of Cover \ Color of the Light	Black (RAL7021)	Gray (RAL7035)	White (RAL9003)
white (5600 K)	033405	036045	036052
blue (470 nm)	033470	036049	036056
orange (606 nm)	033660	036050	036057
yellow (590 nm)	033406	036046	036053
green (528 nm)	033407	036047	036054
red (625 nm)	033408	036048	036055

Aus obigen Varianten ergibt sich folgendes Sortiment:

Item	Description
Ex.	acc. to selection from the above table
031353	CircLED lower part Ø 120 x 65 mm, 1 x KV M16
036106	CircLED lower part Ø 120 x 65 mm, 2 x KV M16
036352	Special cables 2x2.5 mm ²
020669	4-Channel control unit --> page 16
021248	1-Channel control unit --> page 16
020320	Programming device for 4-channel control unit --> page 17
029597	Power supply unit for 4-channel control unit --> page 17
020157	Adhesive and sealant --> Page 18
028303	Joint casting compound --> Page 19
016425	Cold-temperature mortar --> Page 19
018821	Assembly jig for FlatLED / CircLED (is provided on loan from GIFAS)

Other designs are available upon request.

Starting on Page 16, there is an overview of all system components required for a complete **CircLED®** system.

 Detailed installation instructions with pictures of the individual steps are available upon request

System *CircLED*[®] – Different Options and Examples

Blue Lights Provide Accents

Before it was spruced up with lavender and colored gravel, the round-about in Buriet was known as the ugliest by far of its type. Thanks to its new lighting, it could now be at the top of the ranking in a beauty contest.

22 blue *CircLED*[®] traffic circle lights border the Buriet round-about and provide colorful accents at nightfall. At the same time, flagstones made of sandstone are lit up by ten *VisuLED*[®] orientation lights. This not only looks very pretty, above all it also provides for safety by heightening the awareness of the motorists with the points of light.

Also worth noting is the low consumption of power of 3 Watts per *CircLED*[®], as compared to the *VisuLED*[®] that uses 7 Watts. As a result, the traffic circle lights, at a cost of 12 Centimes per Kilowatt hour, average less than 20 Centimes per night.

Ex. Roundabout Buriet in Thal



System Components – Control Units



4-Channel Control Unit

The control unit for all GIFAS systems is designed for 4 output lines. Each channel can be loaded with max. 2.5A. That corresponds to approx. 60 **MarkLED**[®] signal units, 30 **FlatLED**[®] signal units (generally equipped on both sides) or 20 **CircLED**[®] signal units.

- Input: a 230 VAC / 24 power supply device with a nominal output current of 10 A is installed upstream from the control unit.
- Fault messages: a relay with a change-over contact (floating) is assigned to each channel in order to signal faults. The relay drops off if an error has occurred. These fault messages can be randomly set for single (per channel) or cumulative faults by means of a micro-switch.
- External blinking contact: standard equipment includes an external blinking signal (24 VDC / 60 VDC) that can be connected and transferred to the output lines
- Operating mode: the control unit has 5 different modes of operation. The operator can select the operating mode through corresponding external controls.
- Functions: One of the following functions can be assigned to each channel in each mode:
 - Continuous lighting: 100%
 - Blinking: adjustable from 0.1–9.9Hz
 - Dimming: adjustable from 1 - 99%
 - Flashing: adjustable from 1 - 99 ms
- Programming: the optional programming device makes it possible to set and select all of the parameters. Communication is wireless through radio interface. If no programming device is available, all of the parameters can also be configured with the 3 programming buttons on the control panel (4-digit display).

Technical Data:

The 4-channel control panel is built into a GIFAS solid rubber housing, model 2516 with a transparent cover.

Dimensions	250x160x90 mm (WxHxD)
Protection category	IP65
Rated power, max.	420 VA
Input voltage	24 VDC (range 18-40 VDC)
Supply current	10 A, 4 channels @ 2,5 A
Power supply	external

Item	Description
020669	4-channel control unit, ready to be connected in KSV 2516

 Detailed descriptions of the control units are available upon request

Single-Channel Control Unit

A smaller control unit was developed for simple applications with a limited number of signal lights. This single-channel model was designed for only one output line, whereby the output load is maximum 2.5 A.

- Input: the control unit is supplied directly with 230 V mains voltage. The operating voltage of 24 VDC is generated from the input voltage by an internal power pack.
- Error Messages: a floating error message contact is assigned to the output channel.
- External Blink Contact: standard equipment includes an external blinking signal (24-60 VDC) that can be connected and transferred to the output lines
- Operating Mode: the control unit has 2 different modes of operation. The operator can select the operating mode through the corresponding external controls.
- Functions: One of the following functions can be assigned to the output channel in each mode:
 - Continuous lighting: 100%
 - Blinking: adjustable from 0.1 – 9.9 Hz
 - Dimming: adjustable from 1 - 99%
 - Flashing: adjustable from 1 - 99 ms
 An OFF function is also available as standard equipment.
- Programming: all of the parameters can also be configured directly using the 3 programming buttons on the control panel (4-digit display). Programming with a programming device is not possible with the single-channel control unit.

Technical data:

The single-channel control panel is built into a GIFAS solid rubber housing, model 2516 with a transparent cover.

Dimensions	250x160x90 mm (WxHxD)
Protection category	IP65
Input voltage	230 VAC (85-264 VAC)
Output voltage	24 VDC (range 18-40 VDC)
Supply current	2,5 A (1 channel)
Power supply	integrated

Item	Description
021248	1-channel control unit, ready to be connected in KSV 2516

System Components – Power Supply Unit and



Power Supply Unit for 4-Channel Control Unit

A 230 VAC/ 24 VDC power supply unit is installed upstream from the 4-channel control unit. This is used to produce the required output voltage of 24 VDC. The power supply unit is equipped with integrated protection against overloading and short-circuiting, with automatic or manual reset.

The power supply unit conforms to CEE regulations and also has UL and/or CSA approval.

Technical data:

Dimensions	60x124x117 mm (WxHxD)
Protection category	IP20 (IP42 with addition cover)
Protection class	I
Input voltage	230 VAC (100-240 VAC)
Output voltage	24 VDC ($\pm 10\%$)
Output current	10 A
Primary connections	Screw terminals 2,5 mm ²
Secondary connections	Screw terminals 2,5 mm ²
Status display	LED green
Installation	Quick fastening for DIN rail 35mm

Item	Description
029597	Power supply unit MAXI / 230VAC-24VDC / 240W-10A

Programming Device for 4-Channel Control Unit

Programming device with menu guide for set-up, programming and status recognition of the control unit. Communication with the control unit occurs through radio.

All necessary functions can be set up and assigned through the menu structure – as it is used with all mobile telephones. No special knowledge is required to operate it. The connection between the control unit and the programming device is bi-directional, i.e. the current settings can be transferred from one to the other.

The buttons „ \uparrow “, „ \downarrow “, „ \boxtimes “ und „ \checkmark “ are used to navigate the system. The range is approx. 3 m.

The menu is available in 4 languages: German, English, French and Italian.

Technical data:

Dimensions	63x140x31 mm (WxHxD)
Protection category	IP40
Protection class	III
Radio frequency	2400-2483 GHz
Operating voltage	3 VDC, 2 Stk. batteries Typ AA
Life of battery	> 1 year in stand-by mode

Item	Description
020320	Complete programming device for 4-channel control unit

i A detailed datasheet on the power supply unit is available upon request

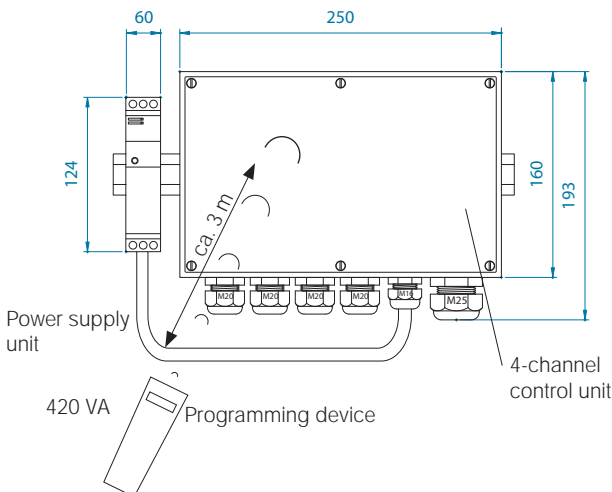

i A detailed description of the programming device is available upon request.

System Components – Special Stranded Cables, Glass Fiber Cord, Sealant



System Components I

General Information

In order to ensure that a system is functional, whether it be a **MarkLED®**, **FlatLED®** or **CircLED®**, system components are always required in addition to the control system. Below we have listed the basic components needed for GIFAS marking light systems; there are also more specialized components that we are always glad to recommend to our customers for specific projects.

a) Special Stranded Cables

For the optical guidance systems you need both stranded cables as supply lines to the individual modules. The stranded cables are available in white or black, whereby the entry point on the lower part of the **FlatLED®** and **CircLED®** as well as of the current collector of the **MarkLED®** have been adapted to fit the diameter of the stranded cables exactly.

Technical Data:

wire	galvanized copper wire
Isolation	PP / VDE0207 part 7 non-halogen Shore hardness D36
Line colors	black, white
Nominal cross-section	2,5 mm ²
Outside Ø	3,7 mm
Nominal voltage	max. 500 Volt

Item	Description
039573	System cables , single-core cable 2.5mm ² , black
039572	System cables , single-core cable 2.5mm ² , white

b) Adhesive and Sealant for the MarkLED® module

The MarkLED® current collector is glued in underground with a sealant and adhesive compound. This compound has to meet numerous criteria such as temperature resistance, acid resistance, etc. It also must harden quickly enough. Our adhesive is a single-component adhesive that vulcanizes itself into an elastic compound as it reacts to the air humidity. It also has no silicone or solvents

Technical Data:

Basis	MS-Polymer
Cross-linking system	Polymerization through air humidity
Temperature resistance	- 40° bis + 90°C
Processing temperature	approx. + 5° bis + 30°C
Color	kieselgrau
Processing	using a hand spray gun
Packaging	Cartridge à 290 ml

Item	Description
020157	Hybrid adhesive and sealant, gravel gray, cartridges @ 290 ml

 Detailed description of the system components available upon request.

System Components – Additional Accessories



System Components II

d) Junction Boxes

In order to get from the control centers to the shoulder, an appropriate supply line has to be pulled in. It starts at the control center and is led through conduits to the shoulder, or under the shoulder respectively. A junction box (usually E30, non-combustible) is installed at that point from where the two special stranded cables are laid on the shoulder.

The type of junction box used depends on the type of supply line, as well as on how many channels lead away from the junction box. We are happy to give you our recommendations, and we have a comprehensive range of products.

You can find our complete range of junction boxes in our brochure "Junction Boxes" (Reg.4).

e) Joint Sealing Compound

Numerous different bituminous sealing compounds have been used, although a very particular type of compound is best for these specific applications, as regards processing, water resistance and durability.

For this application, the recommended joint sealing compound is heated to 160° - 180°C while being stirred constantly. It is poured in through a can with a nozzle or injection lance, whereby excess compound has to be mechanically removed after it has cooled down completely.

Technical Data:

Color	black
Packaging	boxes @ 10 kg ea.
Compound temperature	160° - 180°C
Density	1,7 kg / dm ³

Item	Description
028303	Joint sealing compound Bitumen CTW

f) Guard Plate for *MarkLED*® Module

In winter we often encounter the problem of snow plows driving in and out of tunnels having their blades at the same height as the *MarkLED*® - this results in modules being sheared off and having to be replaced. In order help solve this problem, guard plates were designed, constructed and installed. These guards protect the first *MarkLED*® modules found at the entrance and exit of a tunnel.

The shape and the principle behind the design are shown in the photograph above.

Technical Data:

Type of material	V4A
Dimensions	190x150x24 mm
Fastening	with 4 flat head screws, A4 M8x70 mm (incl. anchors)

Item	Description
024446	Guard plate V4A for MarkLED
024676	M8x70 mm A4 flat head screws for the guard plate
024677	Nylon anchors. M8, for the guard plate

g) Cold Mortar

In order to install the lower part of the *FlatLED*® and *CircLED*®, you need cold mortar to fill in around the lower part. For each lower part, you will need approximately 0.7 l (~.1.17 kg).

Item	Description
016425	Cold mortar (in bags of 25 kg, or 15 l resp.)

i A detailed description of the der system components is available upon request

Be sure to contact us

We look forward to meeting you in person!

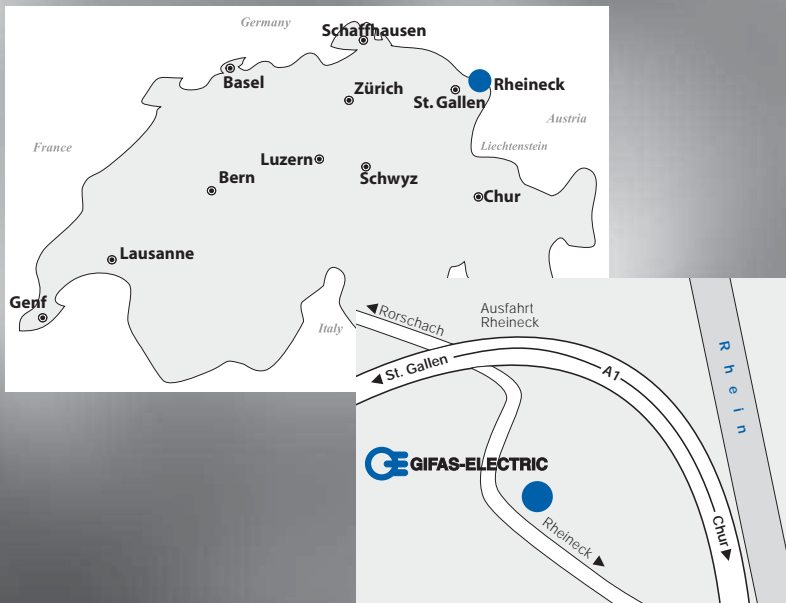

You can find the latest news about our line of products and special solutions, along with our most up-to-date catalog on our Web pages at

www.gifas.ch

Making sure current flows properly

GIFAS-ELECTRIC GmbH
Dietrichstrasse 2
Postfach 275
CH-9424 Rheineck

Telefon +41 71 886 44 44
Telefax +41 71 886 44 49
www.gifas.ch
info@gifas.ch

